

# Terrestrial Heat Repository for Months of Storage (THERMS)

THERMS radial packed-bed thermal energy storage enables cost-effective, long-duration heat storage for industrial decarbonization and renewable integration

---

**US Patent #11,549,761B1**

**Patent Pending**

**Technology Readiness Level (TRL) 6**

---

## Business Problem

Industries that rely on high-temperature process heat face challenges integrating variable renewable energy sources such as solar and wind because of their intermittent nature. For example, these renewable energy sources are unavailable when the sun isn't shining or the wind isn't blowing. This mismatch between energy availability and industrial heat demand often forces reliance on fossil fuels, which contribute to greenhouse gas emissions and expose industries to volatile fuel prices and regulatory risks. Existing energy storage technologies like batteries are costly and unsuitable for long-duration energy storage applications, particularly when heat is the desired product. There is a need for affordable, scalable thermal energy storage solutions that can reliably supply industrial heat while supporting decarbonization and reducing costs.

## Customer Need

Customers want cost-effective, durable and scalable solutions compatible with existing processes.

Shifting energy use from peak renewable generation to periods of high heat demand is critical to maximize renewable use and reduce fossil fuel dependence.

Technologies must minimize maintenance, use earth-abundant materials and integrate well with renewable energy sources.

## Sandia Approach

Researchers at Sandia National Laboratories developed the Terrestrial Heat Repository for Months of Storage (THERMS), a radial packed-bed thermal energy storage system that stores heat in earth-abundant materials such as gravel or rocks. Its radial flow design increases heat transfer area and reduces pressure losses compared with axial flow systems, enhancing efficiency, lowering parasitic losses and minimizing thermal losses. Modular and scalable, THERMS stores and dispatches heat at industrial temperatures (100–750°C) for hours to months. It can be charged with variable renewable electricity converted to heat or direct thermal sources and discharged to diverse industrial heat processes, enabling flexible renewable energy integration.



## Competitive Advantage

THERMS' patented radial flow design improves heat transfer and reduces parasitic power compared with conventional axial packed beds. The innovation has been demonstrated with a 100-kilowatt-hour prototype integrating photovoltaic charging and coffee roasting discharge. It offers a commercially viable long-duration thermal storage solution. Using low-cost, earth-abundant materials and minimal components reduces capital and operational costs. Its modular design supports diverse applications from specialty roasting to large industrial heat. Economic modeling shows competitiveness with 5-year payback periods in markets with high gas prices and carbon credits.

## Technical Benefits

- **Radial flow architecture:** This increases heat transfer area and lowers pressure drop, reducing parasitic losses.
- **Long-duration storage:** This technology enables multi-hour to seasonal thermal storage for reliable heat supply.
- **Modular and scalable:** The design adapts to various heat loads and applications.
- **Reduced thermal losses:** It minimizes heat loss through optimized geometry.
- **Durability:** THERMS uses stable, earth-abundant materials with no cyclic degradation below 500°C to ensure long operational life.

## Industries & Applications

- **Industrial process heat:** THERMS is useful for drying, roasting (coffee, cacao, barley), calcining and chemical processing.
- **Agriculture and greenhouse heating**
- **Food and beverage processing**
- **Water treatment and desalination**
- **Space heating and cooling:** THERMS can be used in residential, commercial, and industrial buildings.

## Next Steps

Sandia is seeking partners to develop and commercialize this technology. For more information, please contact Sandia National Laboratories' Licensing and Technology Transfer office.

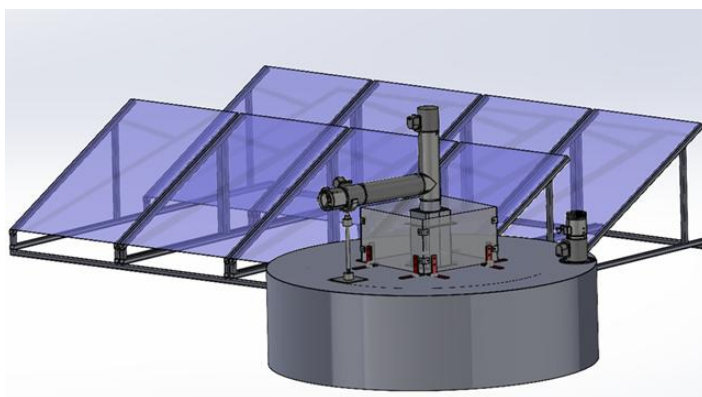

*THERMS integrates renewable energy capture and long-duration thermal storage.*

---

### Contact Us

SD 16476  
SD 16808  
SD 15304



[ip@sandia.gov](mailto:ip@sandia.gov)



[ip.sandia.gov](http://ip.sandia.gov)

---



## Technical Figures

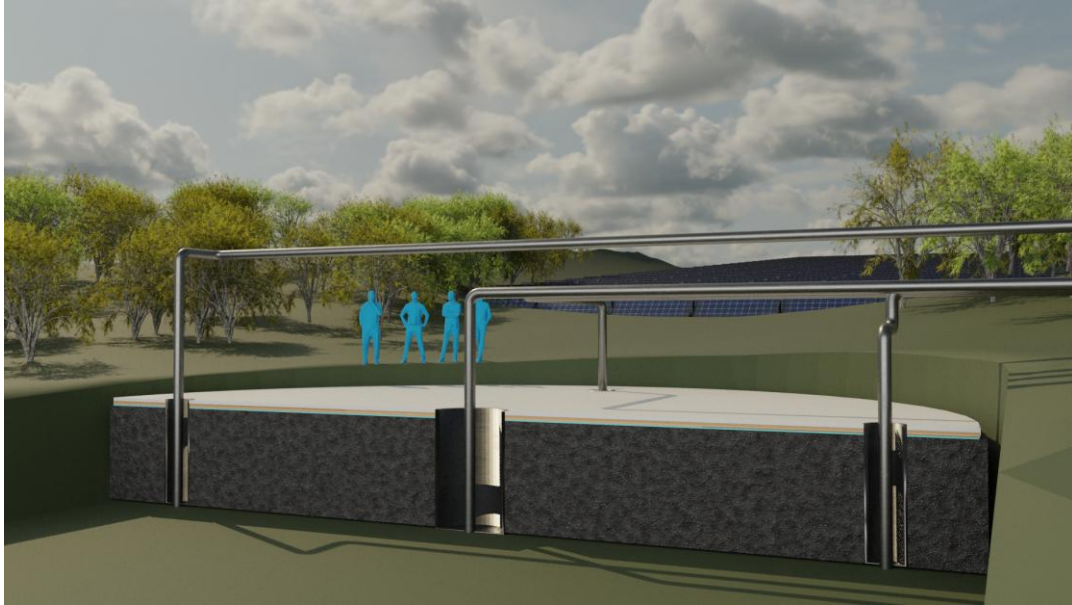

*This illustration shows THERMS in a below-grade application with adjacent photovoltaic solar charging.*

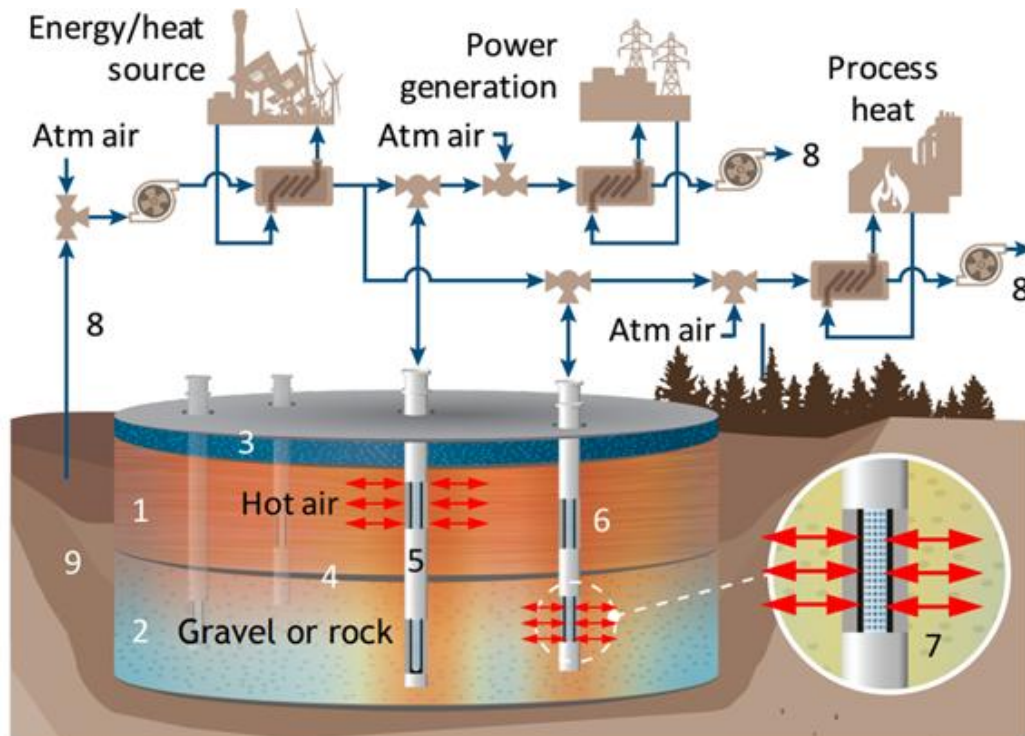

*THERMS captures renewable energy for long-term storage. The energy can be used on-demand for weeks or even months following collection.*



Sandia  
National  
Laboratories



Sandia National Laboratories is a multimission laboratory managed and operated by National Technology & Engineering Solutions of Sandia, LLC., a wholly owned subsidiary of Honeywell International, Inc., for the U.S. Department of Energy's National Nuclear Security Administration under contract DE-NA0003525.